

SMART BOX WITH MODBUS COMMUNICATION

4 analogue and 2 digital inputs and 2 analogue and 2 digital outputs



TECHNICAL DATA

Supply voltage:	19V...26V AC 27V...35V DC
Power consumption:	1,45 VA @ 24V AC, excluding sensor and actuator power supplies
Analogue inputs:	2 x PT1000 2 x 0-10V DC
Digital inputs:	2 x dry contact
Analogue outputs:	2 x 0-10V DC
Digital outputs:	2 x C-NO relay (277V AC 5A Resistive) or (30V DC 3A Resistive)
Indicators LED:	Status, TX and RX
Communication:	RS 485 Modbus RTU
RS485 unit load:	1/8 Unit Load Up to 256 Bus nodes
Speed:	9600 / 19200 / 57600 / 115200
Parity:	Even
Stop bits:	1
Address:	1-247
Terminating:	120Ω via jumper J2
Pull down biasing:	0V dc VSS via jumper J3
Pull up biasing:	5V dc VDD via jumper J4
Ambient temperature:	-30...+60°C
Cable inlets:	1 x PG16 and 1 x PG21
Wiring Terminals:	Pluggable terminal blocks Max 1x2,5 mm ² or 4x0,5 mm ² per terminal
Weight:	335 grams (Packaged)
Dimensions (WxHxD):	185x85x135 mm (Packaged)
Protection class:	IP67 (With suitable cable gland)

CHARACTERISTICS

The Smart Box is a junction box designed to provide; Supplying power and enabling RS485 Modbus RTU communication for the field equipments to which it is connected.

It eliminates cabling from each field equipment to individual DDC panels, and even DDC panels.

Saving meters of cables, DDC panels and troublesome workmanship

A small junction box specially designed for HVAC BMS field equipment

Gains communication capability to field HVAC BMS field equipment

FUNCTION

Smart Box is an IP67 enclosed RS485 Modbus RTU I/O module.

Smart Box has capability to be a slave I/O module for any device which has RS485 Modbus RTU master communication capability.

Setting Smart Box' s Modbus address and baud rate is done by RS485 Modbus RTU commands.

In the case of RS485 Modbus RTU communication failure during approximately for 20 seconds Smart Box will turn off all digital and analogue outputs for BMS HVAC equipment safety.

Analogue input and analogue output terminal blocks have power supply terminals for sensor and actuator power supplies. Smart Box has capability AC/DC power supply. If you prefer to use DC power supply please note that all sensor and actuator power supplies will be DC. The same case is valid for also AC power supply. Simply, main supply used for also sensor and actuator power supplies.

APPLICATION

Smart Box designed and engineered especially for HVAC BMS equipment and systems. It is also good solution for cost effective PLC systems.

MOUNTING

Smart Box is wall-mounted indoors and outdoors.

MAINTENANCE

Smart Box is maintenance-free.

ORDERING EXAMPLE

Item code	Description
Smart Box	I/O Module with RS485 Modbus RTU communication.

SMART BOX WITH MODBUS COMMUNICATION

4 analogue and 2 digital inputs and 2 analogue and 2 digital outputs

SMART BOX INSTALLATION INSTRUCTIONS

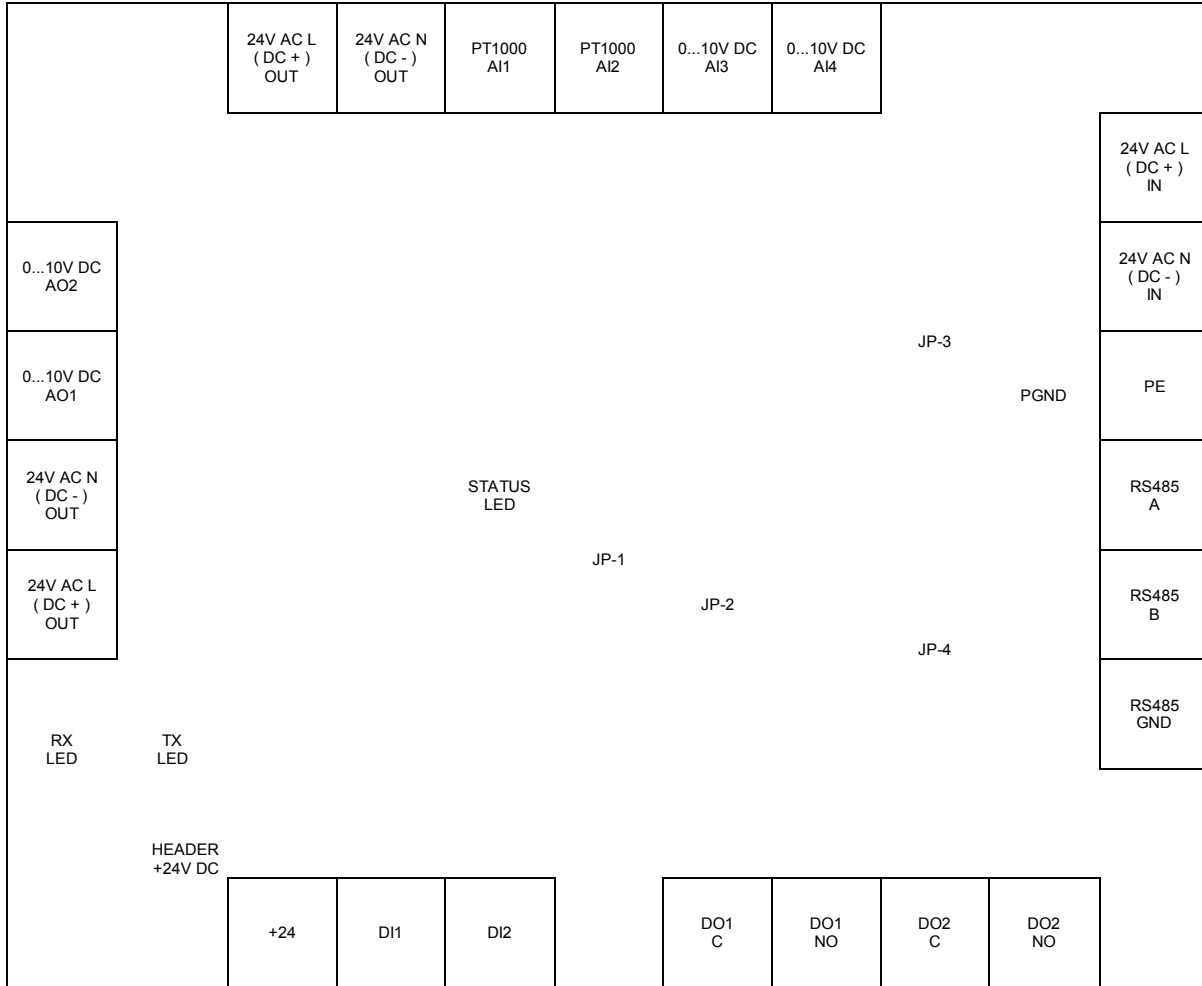

SMART BOX WIRING

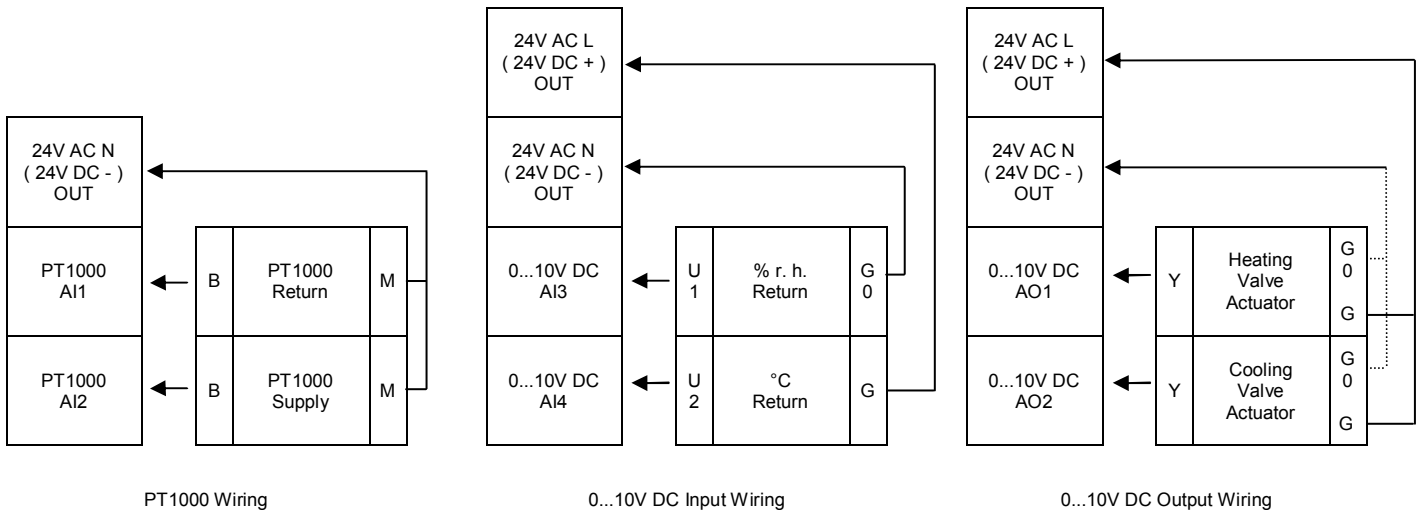

SMART BOX WITH MODBUS COMMUNICATION

4 analogue and 2 digital inputs and 2 analogue and 2 digital outputs

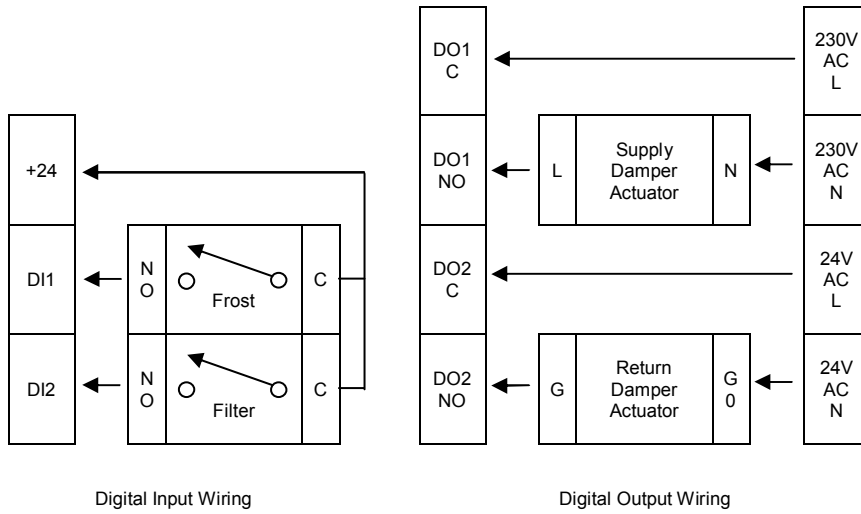

Indicators LED

TX	Transmitting data to master
RX	Receiving data from master
STATUS	Heart beat, normal operating

Header

There is 24V DC Max 50 mA power supply on 2 pin header, even main power supply is 24V AC. Never use jumper on this header. +24V DC pin marked and its neighbour pin is GND on the same header.

Jumpers ON (Plugged)

OFF (Unplugged) Default

Jumper	ON (Plugged)	OFF (Unplugged) Default
JP-1	Modbus address and baud rate setting and temperature calibration	Normal operating
JP-2	RS485 line 120 ohm termination	No line termination
JP-3	Pull down biasing	No pull down biasing
JP-4	Pull up biasing	No pull up biasing
PGND	GND connected to PE	No connection between GND and PE

Serial Port Configuration

Baud rate (JP-1 OFF)	9600 / 19200 / 57600 / 115200
Data bits	8
Stop bits	1
Parity	Even
Flow control mode	None
Modbus data mode	RTU

Setting mode address (JP-1 ON before turn on power supply)	247
Setting mode baud rate (JP-1 ON before turn on power supply)	57600

SMART BOX WITH MODBUS COMMUNICATION

4 analogue and 2 digital inputs and 2 analogue and 2 digital outputs

Factory default Modbus address is the last 3 digit of serial number.
 Example, for serial number 080621A10076, Modbus address is 76.
 Except serial numbers 248, 249, 250.
 Default address for these are 248=1, 249=2 and 250=3.
 Factory default Modbus baud rate is 57600.

Modbus Registers

Coils (0x)	Function	Range	Value
1	0x0001 Digital output #1	On / Off	On / Off
2	0x0002 Digital output #2	On / Off	On / Off
Discrete inputs (1x)	Function	Range	Value
10001	1x0001 Digital input #1	On / Off	On / Off
10002	1x0002 Digital input #2	On / Off	On / Off
Input registers (3x)	Function	Range	Value
30001	3x0001 Analogue input #1 PT1000 x10 Signed	-800...1500	-80°C...150°C
30002	3x0002 Analogue input #2 PT1000 x10 Signed	-800...1500	-80°C...150°C
30003	3x0003 Analogue input #1 Volt x100	0...1000	0V DC...10V DC
30004	3x0004 Analogue input #2 Volt x100	0...1000	0V DC...10V DC
Holding registers (4x)	Function	Range	Value
40001	4x0001 Analogue output #1 Volt x100	0...1000	0V DC...10V DC
40002	4x0002 Analogue output #2 Volt x100	0...1000	0V DC...10V DC

SETTING SMART BOX' S MODBUS ADDRESS AND BAUD RATE (Setting mode by JP-1) [PLC Addresses BASE 1]

- Set JP-1 On
- Turn on Smart Box's power supply
- Status led will verify entering setting mode by blink once
- After status led blink once, Smart Box address will be 247 and baud rate will be 57600
- Be sure that master device online with Smart Box
- Write 1 to Modbus address 3 [use 05 : write single coil, write 1 (on) to address 3]
- Status led will turn on and verify Smart Panel is ready for new address
- Write 100 to Modbus address 40003 (100 is example) [use 06 : write single register, write 100 to address 3]
- Read Modbus address 30003 for verifying new address (100) [use 04 : read input registers, read 100 from address 3]
- Write 0 to Modbus address 3 [use 05 : write single coil, write 0 (off) to address 3]
- Status led will turn off and verify Smart Panel' s addressing is completed
- Write 1 to Modbus address 4 [use 05 : write single coil, write 1 (on) to address 4]
- Status led will turn on and verify Smart Panel is ready for new baud rate
- Write 1 to Modbus address 40004 (1=9600 2=19200 3=57600 4=115200) [use 06 : write single register, write 1 to address 4]
- Read Modbus address 30004 for verifying new baud rate (1) [use 04 : read input registers, read 1 from address 4]
- Write 0 to Modbus address 4 [use 05 : write single coil, write 0 (off) to address 4]
- Status led will turn off and verify Smart Panel' s setting baud rate is completed
- Turn off Smart Box's power supply
- Wait for approximately 10 seconds
- Set JP-1 Off
- Turn on Smart Box's power supply
- See heartbeat by status led
- Settings are finished now, Smart Box' s Modbus address is 100 and baud rate is 9600 baud

If you are a Tridium, Niagara Framework user, we will be glad to share our station for this procedures.